

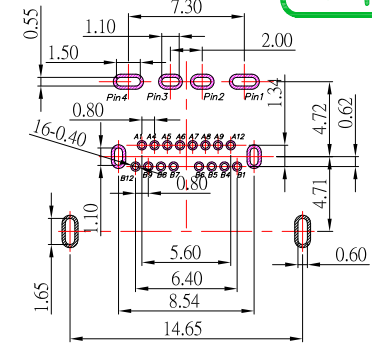

UC-16F-UA-FASx-S410

鍍層厚度：

Blank	1u"
2	15u"
3	30u"



P.C.B. LAYOUT

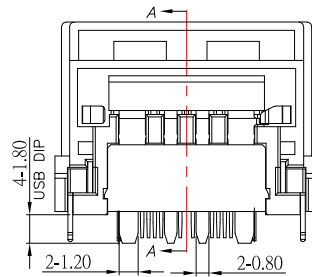
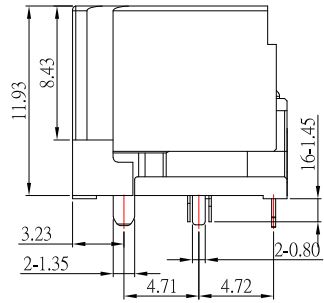
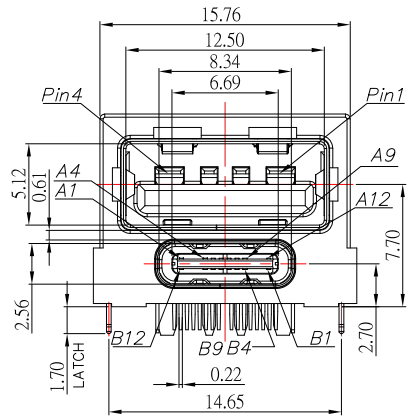
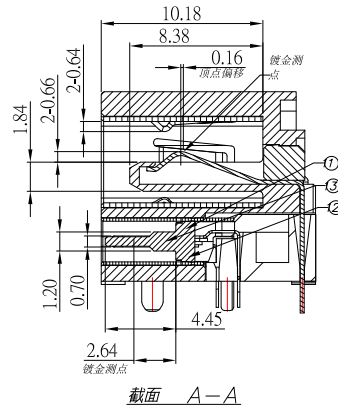
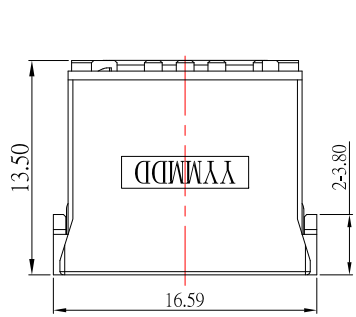

NO.	DESCRIPTION	QTY.	MATERIAL	TREATMENT
③	TYPE C 中夾片	1	SUS	
②	TYPE C 下MD 胶芯	1	LCP	MOLDED COLOR: 橙色
①	TYPE C 上MD 胶芯	1	LCP	MOLDED COLOR: 橙色
⑩	主体塞子胶芯	1	LCP	MOLDED COLOR: 橙色
⑨	USB 塞子胶芯	1	LCP	MOLDED COLOR: 橙色
⑧	TYPE C MD2	1	LCP	MOLDED COLOR: 橙色
⑦	TYPE C 下端子	8	C18400	Au ON TONCTANT AREA; MATTE Sn ON SOLDERAREA;
⑥	TYPE C 上端子	8	C18400	Au ON TONCTANT AREA; MATTE Sn ON SOLDERAREA;
⑤	TYPE_C SHELL	1	SUS	ALL AREA Ni.
④	USB LATCH	2	SUS	ALL AREA Ni.
③	USB2 PIN	4	PHOSPHOR BRONZE	Au ON TONCTANT AREA; MATTE Sn ON SOLDERAREA;
②	USB SHELL	1	SUS	
①	HOUSING	1	LCP	MOLDED COLOR: 橙色

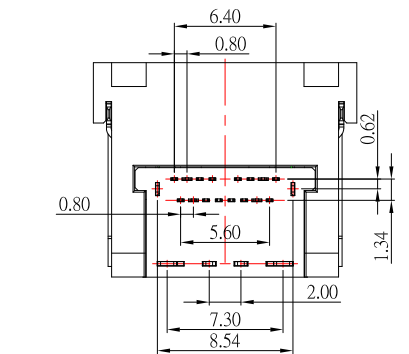

USB 2.0 A/F 引脚定义

引脚	功能
1	V BUS
2	Data-
3	Data+
4	GND

TYPE C/F 引脚定义

PIN NUMBER	A1	A2	A3	A4	A5	A6	A7	A8	A9	A10	A11	A12
SIGNAL NAME	GND			Vbus	CC1	Dp1	Dn1	SBU1	Vbus			GND
PIN NUMBER	B12	B11	B10	B9	B8	B7	B6	B5	B4	B3	B2	B1
SIGNAL NAME	GND			Vbus	SBU2	Dn2	Dp2	CC2	Vbus			GND

NOTES:

- ELECTRICAL CHARACTERISTICS(USB A端) :
 - CURRENT RATING: 7A,
 - INITIAL CONTACT RESISTANCE: 30MΩ Max;
 - INSULATION RESISTANCE: 1000MΩ Min. 500V/DC
 - DIELECTRIC WUTHSTANDING VOLTAGE: 500V AC for MIUNTE
 - OPERATING TEMPERATURE: -40°C~+25°C;
- MECHANICAL CHARACTERISTICS(USB A端) :
 - MATING FORCE: 6~25N;
 - UNMATING FORCE: 10~25N(INITIAL), 8~25N(AFTER 3000 CYCLES);
 - FREQUENCE: 20~30次/min, 3000 CYCLES;
- ELECTRICAL CHARACTERISTICS(TYPE C端):
 - CURRENT RATING: VBUS AND GND CONTACTS RATED AT 7A,
 - INITIAL CONTACT RESISTANCE: 30MΩ Max;
 - INSULATION RESISTANCE: 100MΩ Min;
 - DIELECTRIC WUTHSTANDING VOLTAGE: 100V AC ONE MINUTE.
 - OPERATING TEMPERATURE: -40°C~+25°C;
- MECHANICAL CHARACTERISTICS(TYPE C端):
 - MATING FORCE: 5~20N;
 - UNMATING FORCE: 8~20N(INITIAL), 6~20N(AFTER 10000 CYCLES);
 - FREQUENCE: 200±50 CYCLES/HOUR, 10000 CYCLES;



DRAWN BY:	DATE	MAT'L	TITLE	CONNECTOR
Jack Lu	05/21/24	FINISH	MODLE	90度 TYPE C 母座 + USB 2.0 母座 2 合一 H 11.93
CHECKED BY:	DATE	SCALE	DWG NO.	UC-16F-UA-FASx-S410
Jacky Chen	05/21/24	1 : 1	PART NO.	UC-16F-UA-FASx-S410
APPROVED BY:	DATE	SHEET NO.	1 of 1	
Tony Kao	05/21/24			

TOLERANCE UNLESS OTHERWISE STATED :	Up to 5 ±0.2	Above 5 ~ 15 ±0.3	Above 15 ~ 30 ±0.4	Above 30 ~ 50 ±0.5	Angle ±0.3
	3RD. ANGEL'S	UNITS	MM		

2	更新PIN編號	Jack	052124
1	新增PIN編號	Jack	052024
ITEM NO.	DESCRIPTION	DRAWN	DATE